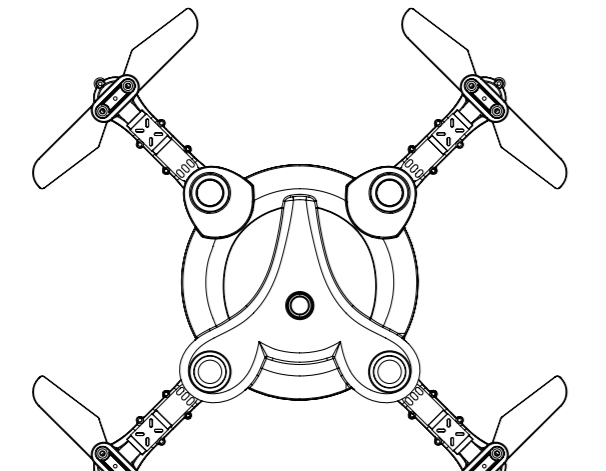
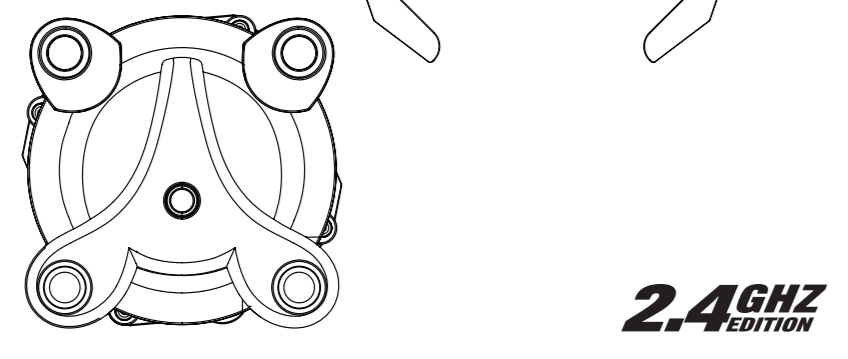

Suitable for ages 14+

USER'S MANUAL

Denver DCH-200

2.4GHZ
FHSS

WWW.DENVER-ELECTRONICS.COM

Please read this instruction manual carefully before start using the product.

English

Notice:

1 Instructions
Please read the user handbook carefully and then keep it in a safe place for future consultation and maintenance.

1.1 Important Notice

(1) This product is not a toy, it's a piece of complicated equipment which integrated with professional knowledge by mechanic, electric, air mechanics, high-frequency transmitter and so on, so it should be installed correctly and adjusted to avoid any accidents. The owner must always operate in a safe manner. If improper operation that caused human injured or property damage, then we DENVER ELECTRONICS A/S accept no liability for any safety duties from operation. As we have no control over the way they maintained, used and operated.

(2) This product is not suitable for users under 14 years of age.

(3) The use of the drone may be prohibited in some areas like train stations, airports, aircrafts, inhabited areas etc. You should check with the authorities whether the use of the drone is permitted in some public or private areas. Always use the drone bearing in mind not to breach people's privacy. We exclude liability for any wrong use of the drone.

(4) We DENVER accept no liability for any safety duties or fines arising from operation, usage or mis-control after the sale of products. Warranty does not cover if drone crashes and get damaged.

1.2 Safety Precautions
Keep away from crowd when flying, since drone flight is a high risk hobby. Mis-assembled or broken main frame or defective electronic equipment or unskilled operation may cause accidents of machine damaged or injured. Please pay special attention to safety operation.

(1) Keep away from people and obstacles
"The flying speed and status of the drone is uncertain, so it may cause potential danger."
When choosing a flying site should stay clear of buildings, trees and power lines. AVOID flying in or near crowded areas. Meanwhile avoid flying in rain, storms, thunder and lightning to protect machinery and parts out of damage.

(2) Keep away from humid environments

Inside of drone is made up of precise electronic components. Stay away from humidity or water vapor to protect machinery and parts.

(3) **Safety operation**
Please fly your drone according to your physical status and flight skill. Fatigue, listlessness and mis-operation will increase possibilities of accidental hazard.

(4) **Keep away from rotating blades**
Keep your face and body as well as all spectators away from the rotating blades. The spinning blades of a model of this type can cause serious injury.

(5) **We recommend flying the drone below 10 meters of height.**

(6) **Keep away from heat**
A drone is made up of metal, fiber, plastic, electronic components, etc. So keep it away from heat and sunshine to avoid distortion, and damage.

1.3 Check List Before First Flight









(1) **Flying field should be in an open space and we suggest at least 5M length *5M wide *3M height.**

(2) **Make sure the receiver and transmitter is fully charged.**

(3) **Please strictly obey the order of turn-on, turn-off before operation. When starting your flight, first turn on the transmitter, and connect power cable of drone last; When finishing your flight, please disconnect the power cable of your drone first, turn off transmitter last. An upset in the order of connection may cause your drone loose control to threaten yourself and others safety. Please follow a correct habit of turn-on and turn-off.**

(4) **Make sure the connection is solid between battery or motor. The ongoing vibration may cause bad connection of power terminal and make the drone uncontrollable.**

List of items

1.aircraft		X1	5.usb charging cable		X1
2.blade		X4	6.battery		X1
3.remote control		X1	7.user's manual		X1
4.phone bracket		X1	8.screwdriver		X1

Remote control and aircraft battery installation and charging instructions
(Only the WIFI version)

 Insert the battery correctly as shown in the illustration (+ / -) of the battery compartment as shown.

Aircraft battery charging

1. Use the USB cable to connect the computer to charge:
USB charging end Connect the battery battery plug, the other end can be connected to the computer's USB port to charge the battery, charging lights off, full light.

2. Connect the aircraft power supply:
Insert the charged battery into the battery holder of the aircraft, and then align the battery plug to the power input socket on the aircraft for power connection.

 The battery is charging

Remote control function name

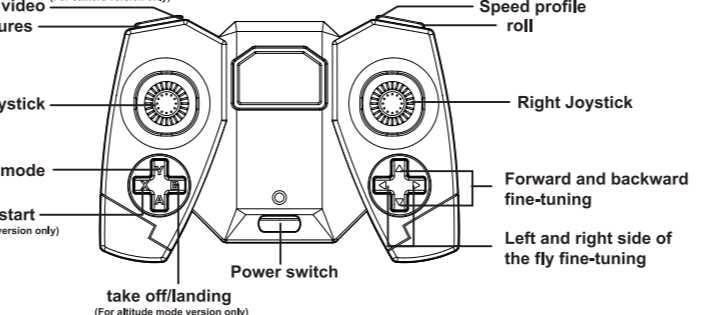

Video (for reference only)
Speed profile
roll
Left Joystick
Right Joystick
Headless mode
one-button start (for all-in-one version only)
Power switch
take off/landing (for all-in-one version only)
Forward and backward fine-tuning
Left and right side of the fly fine-tuning

Control instructions

A key take-off and a key landing
(1) Press (2) or the left joystick to take off and land
Left and right hand throttle switch function: Hold down the A key, and open the remote control power, can be converted into the right hand throttle.

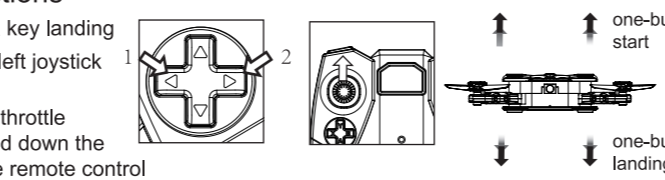

Flight control

A.Throttle (Left Joystick)

Push the left lever up The aircraft rose
Push the left lever down The aircraft descends

B.Forward and backward (right Joystick)

Push the right lever up Aircraft forward
Push the right lever down The aircraft retreated

C.Left and right side of the fly

Push the right control lever to the left The aircraft flew to the left
Push the right control lever to the right The aircraft flew to the right

D.Turn left and right

Push the left lever to the left Aircraft turn left
Push the left lever to the right Aircraft turn right

Fine-tuning control

Forward and backward fine-tuning

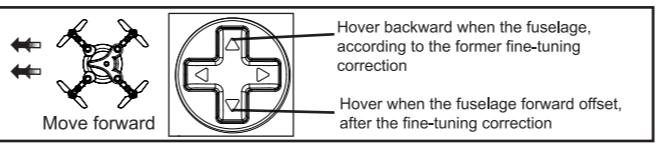

Hover backward when the fuselage, according to the former fine-tuning correction
Hover when the fuselage forward offset, after the fine-tuning correction

About fine-tuning

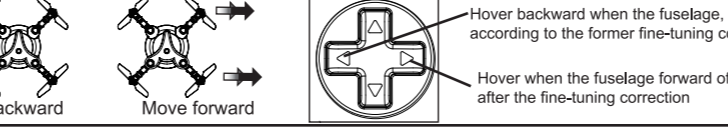

6. Headless mode of direction definition and mode selection

When switching to headless mode, the aircraft will abandon its front, rear, left and right orientations, and reposition the front and back with the remote control as the reference point. For example, when the right control lever is pushed forward, the aircraft will fly away from the remote control.

1. Direction before takeoff Definition: The forward direction of the aircraft in front of you, the remote control on the tail of the direct flight and then press a key to take off, that is, complete the flight headless mode direction definition.

2. When flying, press the headless mode, the remote control continuously emits a "Di Di ..." sound, the aircraft lights flashing quickly into the headless mode. Press the remote control again to send out "Di" and exit the headless mode.

Speed profile selection

 Speed is to forward, back and left and right side of the flight is divided into two speeds, the remote control to open the power supply default after the slow file, press the accelerator remote control issued "flute, flute" twice faster, then click to issue "flute" soon returned to slow. (Recommended for beginners with slow file operation)

Gyroscope calibration

1. Reset setting is the six-axis gyroscope on the aircraft level reset, and reset the remote control fine-tuning role.

2. Before the operation of the aircraft in a horizontal position (if the tripod deformation, the aircraft four corners have a high and low reset after the aircraft take-off will affect the stability) and then the remote control as shown below down two seconds after the remote control issued a "flute" two sound, the aircraft quickly within the light a few times, said the reset is set.

Emergency shutdown

If there is danger during flight, emergency stop can be shown as shown, the throttle to the minimum, while the next "X" button, the aircraft immediately stop running. This function does not attempt to operate when the aircraft is flying at high altitude. No, the side aircraft will fall quickly.

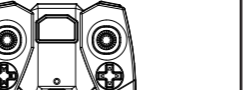

3D flip action instructions



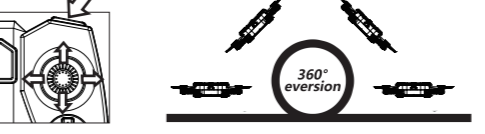





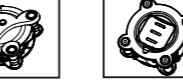
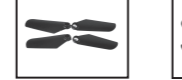

When the basic movements are very skilled when you can play some thrilling rolling action. First of all, the aircraft flew more than 3 meters above the height, the first press (Figure) roll button, and then push the right control rod to make a move. Back or left and right side of the fly, the direction of the aircraft according to the instructions issued by a 360° Roll action.

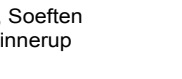

Problem - solving guide

problem	The reason	Approach
remote control The status light does not light	1. On / Off is in the "OFF" position 2. Do not insert the battery with the correct electrode indication 3. The battery is exhausted	1. Turn ON / OFF the "ON" position 2. Check and make sure that the battery is inserted in accordance with the positive and negative terminals indicated by the battery compartment 3. Replace the batteries with new ones
Can not control	1. The remote control is not turned on 2. The aircraft power supply is not connected 3. Remote control on frequency is not successful 4. The wind is too big	1. Turn the remote control on / off to the "ON" position to make the remote control ready for flight 2. Check the aircraft power supply connection 3. Turn off the remote control and re-frequency the aircraft 4. Don't fly in the presence of wind, the wind will cause limitations of the aircraft, or interfere with your control
Aircraft Can not be raised	1. Rotor speed is too slow 2. Aircraft battery power is low	1. Push the UP / DOWN lever up 2. Charge the aircraft to saturation
Aircraft Soon landed	You will pull up / down the joystick too quickly	Slowly raise / lower the lever to allow the helicopter to land slowly

Product main accessories name

ALL RIGHTS RESERVED, COPYRIGHT DENVER ELECTRONICS A/S

Electric and electronic equipment and included batteries contains materials, components and substances that can be hazardous to your health and the environment, if the waste material (discarded electric and electronic equipment and batteries) is not handled correctly.

Electric and electronic equipment and batteries is marked with the crossed out trash can symbol, seen below. This symbol signifies that electric and electronic equipment and batteries should not be disposed of with other household waste, but should be disposed of separately.

As the end user it is important that you submit your used batteries to the appropriate and designated facility. In this manner you make sure that the batteries are recycled in accordance with legislation and will not harm the environment.

All cities have established collection points, where electric and electronic equipment and batteries can either be submitted free of charge at recycling stations and other collection sites, or be collected from the households. Additional information is available at the technical department of your city.

DENVER
www.denver-electronics.com



Imported by:
Inter Sales A/S
Omnia 5A, Søeløften
DK-6392 Hinnerup
Denmark
www.facebook.com/denverelectronics

Hereby, Inter Sales A/S declares that the radio equipment type DCH-200 is in compliance with Directive 2014/53/EU. The full text of the EU declaration of conformity is available at the following internet address: <http://www.denver-electronics.com/denver-dch-200/>